



INSTRUCTION MANUAL

AL-300
Infuse Only Pump

QUICK START

Assumes that the pump was not previously programmed with a multiple Phase Pumping Program.

- Plug in the pump.
- Press the power switch to turn on power.
- Press any key to stop the display from blinking.

Setup Pumping Parameters

To Change Numbers:

- Use the up-arrow keys to increment individual digits.
- Move the decimal point: Simultaneously press the 2 up-arrow keys under the 2 digits next to the decimal point position to set or clear it. Or, press and hold the left-most up-arrow key for at least 1 second. When the digit increments from 9 to 0, the decimal point will begin to shift. Release the key when the decimal point is correct.
- Press any non-arrow key, or wait 2 seconds, to enter the new setting. The display will blink when a new value is entered and stored in memory.

Set the Syringe Inside Diameter:

- Momentarily press the Diameter key. Set the inside diameter of the syringe in millimeters (mm).

Set the Pumping Rate:

- Momentarily press the 'Rate' key.
- To change the pumping rate units:
 - Momentarily press the 'Rate' key again. The display will show: **Units**
 - Press any up-arrow key to select the next available rate units while the units LEDs are blinking.
 - Press any non-arrow key, or wait 2 seconds, to set the rate units.
- Set the pumping rate. If the pumping rate is out of range, the display will show: **err**

Load the Syringe

- Press in the white drive-nut button to move the pusher block.
- Lift and turn the syringe clamp away from the syringe holder block.
- Position the syringe on the pump with the flange to the left of the syringe holder block.
- Lift and turn the syringe clamp onto the syringe barrel.
- Move the pusher block next to the syringe plunger.

Prime / Purge

- Press and hold the 'Start/Stop' key for one second. Release to stop. The display will show: **PURG**
While infusing at the top speed.
- Press and hold the **↔** key to reverse the pump and release the pusher block if jammed.

Start the Pump

Momentarily press and release the 'Start/Stop' key to start or stop the pump.

While Pumping

- The pumping rate can be changed.

Pump Reset

Press and hold the right-most up-arrow key while turning on power to the pump.

CONTENTS

QUICK START	B
Setup Pumping Parameters	b
Load the Syringe	b
Prime / Purge	b
Start the Pump	b
While Pumping.....	b
Pump Reset	b
ABOUT THIS MANUAL	1
INTRODUCTION	1
Features	1
Notes and Warnings.....	1
Parts List.....	1
Unpacking	2
INSTRUMENT DESCRIPTION	2
Glossary of Terminology and Concepts	2
Parts of the Pump.....	2
*The drive release knob and other parts subject to normal wear are not covered by the warranty.	
2	
Parts of a Syringe	3
Terminology.....	3
Setup	3
Loading Syringes	3
User Interface	4
OPERATING INSTRUCTIONS.....	7
Syringe Inside Diameter	7
Operating the Pump	8
Purging.....	8
Changing the Pumping Rate & Direction While Pumping.....	8
Volume Dispensed.....	9
SETUP CONFIGURATION.....	9
REAR OF PUMP.....	9
TROUBLESHOOTING AND MAINTENANCE	9
ACCESSORIES.....	10
SPECIFICATIONS.....	10
CUSTOM APPLICATIONS.....	10
APPENDIX A: SYRINGE DIAMETERS & RATE LIMITS	11
WARRANTY	13
Claims and Returns	13
Repairs.....	13

Copyright © 2024 by World Precision Instruments. All rights reserved. No part of this publication may be reproduced or translated into any language, in any form, without prior written permission of World Precision Instruments, Inc.

ABOUT THIS MANUAL

The following symbols are used in this guide:



This symbol indicates a CAUTION. Cautions warn against actions that can cause damage to equipment. Please read these carefully.



This symbol indicates a WARNING. Warnings alert you to actions that can cause personal injury or pose a physical threat. Please read these carefully.

NOTES and TIPS contain helpful information.

INTRODUCTION

The AL-300 is a general purpose single syringe pump capable of infusing at digitally set pumping rates. It is controlled from a microcontroller based system which drives a step motor, allowing a wide range of pumping rates calibrated to the inside diameter of the loaded syringe. The syringe is driven from a drive-screw and drive-nut mechanism.

Features

- Infusion pumping of syringes up to 140 mL.
- Pumping rates from 0.73 μ L/hr with a 1 mL to 1500 mL/hr with a 60 mL syringe.
- Display of infused volume.
- Non-volatile memory of all operating parameters.
- Power Failure Mode: Re-starts pumping after a power interruption.

Notes and Warnings

- Read this instruction manual before using the pump
- No user serviceable parts are inside.
- Disconnect power from the pump when connecting or disconnecting cables.
- Do not immerse the pump in liquid.
- Install on a stable surface.
- Keep hands and loose clothing away from the pumps moving parts.
- The pump can automatically start when the Pumping Program is operating or when attached to an external control device.
- Prevent liquids from entering openings in the rear of the pump.
- Use only with the supplied power supply connected to a power source as specified on the power supply label.
- Do not push objects of any kind into the chassis openings, except for appropriate cables and connectors.
- If the pump becomes damaged, do not use unless certified safe by a qualified technician. Damage includes, but is not excluded to, frayed cords and deterioration in performance.
- Discharge static from control cables before connecting by touching the cable to ground.
- Before touching the pump, discharge static by touching ground

Parts List

After unpacking, verify that there is no visible damage to the sensor. Verify that all items are included:

- (1) One of the following external unregulated power supply adapters: 120V AC 60 Hz, 220V AC 50 Hz, 240 V AC 50 Hz, or other custom specified power supply. Output: 12V DC @ 1000 mA (or compatible regulated power supply).
- (1) Instruction Manual

Unpacking

Upon receipt of this instrument, make a thorough inspection of the contents and check for possible damage. Missing cartons or obvious damage to cartons should be noted on the delivery receipt before signing. Concealed damage should be reported at once to the carrier and an inspection requested. Please read the section entitled "Claims and Returns" on page 15 of this manual. Please contact WPI Customer Service if any parts are missing at 941.371.1003 or customerservice@wpiinc.com.

Returns: Do not return any goods to WPI without obtaining prior approval (RMA # required) and instructions from WPI's Returns Department. Goods returned (unauthorized) by collect freight may be refused. If a return shipment is necessary, use the original container, if possible. If the original container is not available, use a suitable substitute that is rigid and of adequate size. Wrap the instrument in paper or plastic surrounded with at least 100mm (four inches) of shock absorbing material. For further details, please read the section entitled "Claims and Returns" on page 15 of this manual.

INSTRUMENT DESCRIPTION

Glossary of Terminology and Concepts

When a device has as many features as the Aladdin series, understanding its operation could be a daunting task at first. By understanding the key concepts and terminology used in this manual, the operation of the AL-300 will become quite intuitive. Every effort has been made to design the AL-300 with a consistent and intuitive user interface.

To facilitate and enhance your understanding of the AL-300's operation, please take the time to familiarize yourself with the basic concepts below:

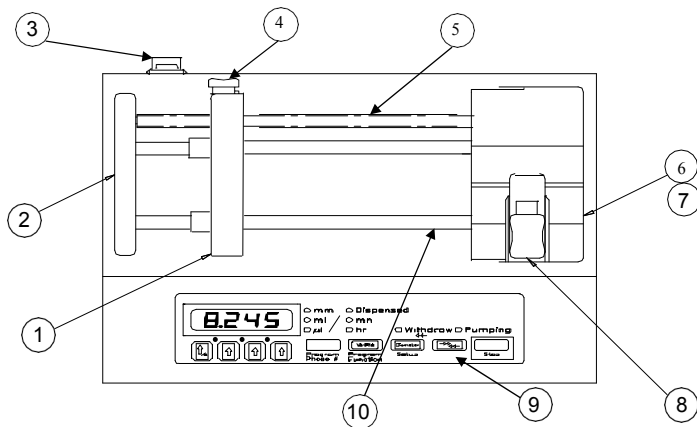

Fig. 1—Aerial view of the pump.

Parts of the Pump

1. Pusher Block
2. End Plate
3. Power On/Off Switch
4. Drive-Nut Button
5. Drive-Screw
6. Syringe Holder Block
7. 'V' Slot (on Syringe Holder Block)
8. Syringe Clamp
9. Keypad / User Interface
10. Guide Rod (2 guide rods)

*The drive release knob and other parts subject to normal wear are not covered by the warranty.

Parts of a Syringe

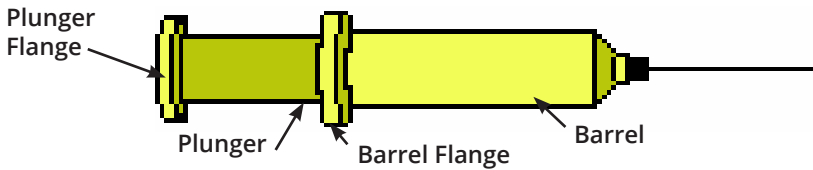

Terminology

Momentary Press

A quick press, less than 1 second, then release of a key on the keypad.

Display Blink

A momentary blanking of the LCD display. This indicates that the new data entered by the user is valid and has taken effect.

Setup

1. Place the pump on a stable surface.
2. Plug the round connector end of the supplied power supply adapter into the power plug located on the lower right of the pump's rear. See section 8, Rear of Pump, for a diagram of the rear of the pump. Plug the other end of the power supply adapter into an appropriate electrical outlet. The pump will be powered when the bottom of the power switch, located on the upper right of the rear of the pump, labeled '1', is pressed. The red indicator on the switch is visible when the power switch is in the 'on' position. After power is applied to the pump, the pump's display will flash.
3. Next, the Pumping Parameters can be entered. Before the pump can be started, the pump needs the measurement of the inside diameter, in millimeters (mm), of the syringe that will be loaded. The syringe diameter is entered using the keypad on the front panel of the pump.
4. Finally, the syringe can be loaded and the pump started.

Loading Syringes

The syringe is loaded by securing the barrel and the pusher flange as follows:

1. Press in fully the white **drive-nut button** on the **pusher block**, releasing the block. Taking care not to drag the drive-nut on the drive-screw, slide the block away from the syringe holder, providing sufficient space for the loaded syringe. Then release the white button.
2. Lift the **syringe clamp** above the **syringe holder block**. Turn it 1/4 turn and then lower it onto the syringe holder block. The syringe clamp should be out of the 'V' slot.
3. Load the syringe with the **barrel** over the syringe holder and the syringe **plunger** towards the middle of the pump. Place the barrel on the syringe holder, in the 'V' slot, with the **barrel flange** to the left of the syringe holder block.
4. Lift the syringe clamp to slightly above the height of the syringe barrel and then turn the syringe clamp 1/4 turn back to its original position and lower it onto the syringe barrel.
5. Press the white drive-nut button to slide the pusher block against the syringe plunger. Release the white drive-nut button.

==> To unload the syringe, reverse the instructions for syringe loading.

User Interface

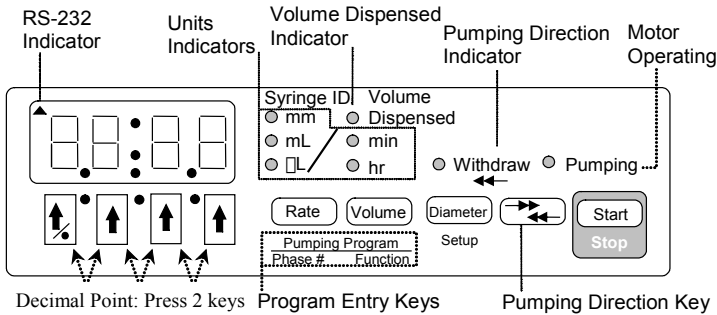

Fig. 2—Front panel

Entering Values

When applicable, values can be changed by either displaying the current value, then using the arrow keys, or from a computer connected to the pump. The new value will be stored in the pump's non-volatile memory, meaning that the new value will not be lost the next time that power is applied to the pump. The only exception is when the pumping rate is changed from an attached computer while the Pumping Program is operating. In this case the new pumping rate will not be stored in non-volatile memory.

A displayed value can be changed by pressing the arrow keys below each digit. If the value to be changed is not currently displayed, when applicable, press the key associated with the required value. The display will show the setting's current value and its units, if any. While the current value is being changed, the unit LED associated with the value, if any, will blink. Except where noted, the new value is stored, and/or the selected operation takes effect when either

1. A non-arrow key is pressed, or
2. After a 2-second delay since the last arrow key was pressed.

If the new value is valid and different from the original value, the display will blink, indicating that the new value was stored. Otherwise, if the value was invalid, an error message will be displayed. Pressing any key clears the error message and restores the original value.

In general, if a parameter has 2 values, off and on, they are represented by "0" and "1", respectively.

LCD Display

The display consists of a 4-digit reflective LCD display. This is the general purpose user display device for displaying floating point values, functions and parameters. The colon (:) is used for displaying time or for separating function abbreviations from their parameter values.

LEDs

To the right of the LCD are 8 red, round, LED indicators. The first 2 columns display the units of the displayed values. Units are expressed using 1 or 2 LEDs. For instance, "mL / hr" is expressed by lighting the "mL" and the "hr" LEDs.

LED	Description	LED	Description
mm	Millimeters	μL	Microliter
mL	Milliliters	min	Minute
Dispensed	Volume dispensed displayed	hr	Hours
Withdraw ←←	Pumping Direction Lit: Withdraw Not lit: Infuse Blinking: "Sticky Direction"		
Pumping	Lit: Motor is operating Not lit: The Pumping Program is stopped or executing a Pause Function Blinking: The Pumping Program is paused		

Up Arrow and Decimal Point Keys

Each of the four digits in the display is associated with the up-arrow key directly below it. When applicable, the up-arrow key is used to increment the value of that digit, or advance to the next setting.

Each press of up-arrow keys increases digits by 1, up to 9, and then back to 0. Hold down arrow keys for continuous incrementing of digits. With fixed range value parameters, such as on/off parameters, arrow keys scroll up to the maximum value, then back to the minimum value.

When changing a parameter's units, each press of any arrow key will change the unit's LEDs to the next unit selection.

When the display blinks, the new value is stored and takes effect. This will occur when a non-arrow key is pressed or after a 2 second delay since the last key press.

Decimal Point

There are 4 decimal point positions, each to the right of a digit in the display. The right-most decimal point is not displayed, indicating whole numbers. To set or clear the decimal point, simultaneously press the 2 up arrow keys under the 2 digits left and right of the decimal point position.

Alternatively, to move the decimal point position, use the left-most arrow / decimal point key (↑/●).

Press and hold this key for at least 1 second and wait until the left-most digit scrolls past '9' to '0'. While continuing to hold this key, the decimal point will shift 1 position to the right. After the right-most decimal point position, the decimal point will shift to the first decimal point position. Release the key when the decimal point is in the required position.

'Diameter' and 'Setup' Key

The 'Diameter' key allows the syringe inside diameter to be viewed and set. While being displayed, the 'mm' LED is lit. Momentarily pressing this key will display the current diameter setting. With the Pumping Program stopped, pressing the up arrow keys will change the current diameter (See "Up Arrow and Decimal Point Keys" on page 5). The 'mm' LED will blink while the diameter is being changed.

If the 'Diameter' key is pressed and held, 'Setup' mode will be entered. (See [sec. 'Setup'](#)).

"Rate" Key

The 'Rate' key displays the pumping rate. With the pump stopped, another press of the 'Rate' key will switch between the 'Rate' display and the select rate units mode.

Use the up-arrow keys to change the pumping rate (see [sec. 5.4, Up-Arrow Keys and Decimal Point](#)). The rate units will blink while the rate is being changed. If the new pumping rate entered is valid, it takes effect when the display blinks after a 2 second delay or when a non-arrow key is pressed.

See section “Syringe Diameters and Rate Limits”, for a list of minimum and maximum pumping rates for different syringes. A pumping rate of 0.0 will stop the pump. If the new pumping rate is out of range of the pumping rate limits for the syringe diameter, the display will show . Pressing any key clears the message and returns to the previous pumping rate.

Pumping Rate Units

The pumping rate units can only be changed when the  Pumping Program is not operating. If the currently selected function allows selection of rate units (“RATE” function), a momentary press of the “Rate” key will enter Rate Units Change mode. The 2 LEDs representing the units will blink and the display will show .

Each press of any arrow key selects the next rate units, as indicated by the blinking units LEDs. When the required rate units are blinking, press any non-arrow key or wait 2 seconds. The display will blink, indicating the rate units are stored. The rate units are stored in the currently selected Program Phase. The rate units can be independently set for each Phase with a “RATE” function.

“Volume” Key

The ‘Volume’ key displays the ‘Volume Dispensed’. The ‘Volume Dispensed’ LED and the current volume units LED will be lit. The units of the volume are set according to the syringe diameter, but can be changed.

Clearing “Volume Dispensed”



With the Pumping Program stopped, display the “Volume Dispensed”. Pressing and holding any up arrow key for one second will reset the infusion and withdrawal dispensed volumes to 0.

Changing Volume Dispensed Units

With the “Volume Dispensed” 0.000 displayed, press any up-arrow key to enter “Set Volume Units” mode.

The display will show:  and the Volume units LED will blink. Press any up-arrow key to toggle the volume units between ‘mL’ and ‘µL’ while the units LED is blinking.

Reverse Purge Key

The pumping direction key, , is used to un-jam the pusher block after an over infusion, making it difficult to release the nut block. Press and hold the direction key for at least 1 second to reverse purge the pump until the pusher block is released. Release this key to stop the pump. While this key is held, the display will show: . The Withdraw and Pumping LED’s will be lit during the reverse purge.

“Start”/“Stop” Key

The ‘Start/Stop’ key starts or stops the Pump’s operation. Pressing this key switches between Pumping and the Pump stopped. The ‘Pumping’ LED will indicate that the Pump is pumping.

Purge Mode: Purge begins after this key is held for one second, and continues until the key is released, stopping the pump. While purging, the display will show: 

“Setup” Key

The secondary function of the “Diameter” key is “Setup”. While the Pumping Program is not operating, press and hold the “Diameter” key until the first setup configuration parameter, “Power Failure Mode”, is displayed: .

The display will consecutively display, for about 2 seconds, each Setup Configuration parameter and its current setting. Pressing any non-arrow key will immediately advance to the next Setup Configuration parameter.

Press an arrow key under the parameter’s value to change the value. To store the new value, press any non- arrow key or wait 2 seconds. If the parameter value differs from its previous value, the display will blink and the new value will be stored and takes effect immediately.

The next parameter, if any, will then be displayed. After the last parameter, the display reverts back to the syringe diameter. See section 7, Setup Configuration for a complete description of the Setup Configurations.

Special Power-Up Functions

The following special functions are accessed by pressing the relevant key, while turning on power to the pump.

Firmware Version Display

To display the pump's firmware version, press the left-most up-arrow key (↑/●) while turning on power to the pump. The display will show: , where 'n.nn' is the firmware version number. Pressing any key will clear the display.

Reset Pumping Program

To clear out the current Program Function setups, press the **right-most arrow key** (→) while turning on power to the pump. The display will show: . Pressing any key will clear the display.

With a pump with as many complex features as the Aladdin, it is easy for a novice user experimenting with the pump's setup to get the pump into a 'weird' state. Performing this reset function will bring the pump out of a 'weird' state.

Error and Alarm Messages

If the value entered is beyond the pump's capabilities or is invalid, or an operational problem occurred, one of the following error or alarm messages will be displayed:



Value entered is "Out Of Range" of the pump's operational limits. Verify that the pumping rate and/or the syringe inside diameter setting are correct.



Key pressed is not currently applicable.



Indicates pumping rate or volume units change mode. The units LED's will also be blinking. Press any up-arrow key to change the units.



Indicates that the pump is purging. Displayed while holding down the 'Start/Stop' key.



Indicates a reverse purge. Displayed while holding down the direction key.



OPERATING INSTRUCTIONS

Before the pump can be operated, the pumping data must be setup. The syringe inside diameter and a non-zero pumping rate needs to be set. The operation of the pump can then be started by pressing the "Start / Stop" key.

Syringe Inside Diameter

The syringe inside diameter can only be set while the Pumping Program is stopped. Use the arrow keys to set the diameter value. While the diameter value is being set, the "mm" LED will blink. The new diameter value is stored after pressing any non-arrow key, or after a 2 second delay.

Valid syringe diameters are from 0.1 mm to 50.0 mm. If the diameter is out of this range, the display will show . Pressing any key restores the diameter display to its previous value. Changing the syringe diameter will not zero any current settings. "Appendix A: Syringe Diameters & Rate Limits 11" on page i is a representative list, for reference, of syringe diameters for various syringe manufacturers and syringe sizes.

Default Volume Units

The units of the accumulated infusion and withdrawal volumes and the "Volume to be Dispensed" are set according to the diameter setting.

NOTE: A change in the volume units will affect all "Volume to be Dispensed" settings in the Pumping Program. If the default volume units are changed (see next section), the selected volume units will remain in effect until a reset function is performed.

From 0.1 to 14.0 mm	Syringes smaller than 10 mL:	Volume units are "µL"
From 14.01 to 50.0 mm	Syringes greater than or equal to 10 mL:	Volume units are "mL"

Changing Volume Units

The Volume Units used for accumulated volumes and the "Volume to be Dispensed" settings can be changed to either 'mL' or 'µL'. Volume Units can only be changed while the Pumping Program is stopped. A change in the Volume Units will affect all "Volume to be Dispensed" settings in the Pumping Program.

To change the Volume Units, display the "Volume Dispensed" by pressing the "Volume" key once or twice. The current Volume Units and the "Dispensed" LED will be lit.

Set the Volume Dispensed to 0.000 if it is not zero: Press and hold any up arrow key until the Volume Dispensed is set to 0.000.

Now, pressing any up arrow key will change the display to **Units** and the current Volume Units will blink.

Then, press any up arrow key to switch the Volume Units between 'mL' and 'µL'. Press any non-arrow key or wait 2 seconds to enter the new Volume Units. The display will blink when entered. The selected Volume Units will remain in affect and override the default Volume Units. Changing the diameter will no longer change the Volume Units. Performing a system reset will cancel the override and allow the Volume Units to change to the default Volume Units when setting the syringe diameter.

Operating the Pump

When the "Start/Stop" key is pressed, the Pump will begin pumping, and the 'Pumping' LED will be lit. The pump will pump continuously at the set pumping rate until stopped.

Either the pumping rate, "Volume Dispensed", or syringe diameter can be displayed while pumping. Press the relevant key to change the display. The pumping rate can be changed while pumping.

WARNING: THE AL-300 DOES NOT HAVE STALL DETECTION. THE PUMP MUST BE STOPPED MANUALLY WHEN THE SYRINGE IS EMPTY OR IF THE MOTOR FORCE IS EXCEEDED. THE WHITE DRIVE NUT BLOCK CAN BE DAMAGED WHEN THE PUMP IS OPERATING WHILE THE MOTOR CANNOT TURN. THIS WILL VOID THE WARRANTY AND REPLACEMENT OF THE DRIVE NUT BLOCK WILL NOT BE COVERED.

Purging

To purge the syringe, with the Pumping Program stopped, press and hold the “Start/Stop” key. The Pumping Program will start, then after one second purge will begin. The pump will pump at its top speed in the currently set direction. Purging will continue until the “Start/Stop” key is released, then the pump will stop. While purging the display will show: **PURG**

Press and hold the direction key  to perform a reverse purge. The display will show: **←**

Changing the Pumping Rate While Pumping

To change the pumping rate, display the pumping rate, and then use the up-arrow keys. The rate units will blink while the rate is being changed. Rate units cannot be changed while pumping.

The new rate is stored after a 2 second delay or by pressing a non-arrow key. If the new rate is within the operating range of the pump, the display will blink and the new rate will be stored in memory and the pump will begin pumping at the new rate. If the new rate is out of the operating range of the pump, the display will show **ERR**. Pressing any key clears the message and restores the previous rate.

Volume Dispensed

The accumulated Volume Dispensed can be displayed at any time by pressing the Volume key. The display will show the total accumulated volume pumped with the ‘mL’ or ‘μL’ LED lit and the ‘Dispensed’ LED lit. Volume is computed based upon the syringe inside diameter setting.

The “Volume Dispensed” accumulations, for infusion and withdrawal, are reset to 0 when:

- With the pump stopped, pressing and holding any up arrow key while displaying the “Volume Dispensed”.
- The syringe diameter is changed.
- The accumulated Volume Dispensed rolls over from 9999 to 0.
- The pump is powered on.

SETUP CONFIGURATION

To change or view the setup configuration, the Pumping Program must be stopped. Press the "Diameter"/"Setup" key until the first parameter, "PF", is displayed. After 2 seconds, or when any non-arrow key is pressed, the next parameter will be displayed (see "Setup" on page 3). The Setup Configurations will be displayed in the following order:

PF: n Power Failure mode, where "n" is the current setting: '0' = Disabled, '1' = Enabled.

When enabled, if the Pump was pumping when power to the pump was disrupted, the Pump will automatically start pumping when power is reconnected to the pump. The accumulated volume will be reset to 0. Pressing any key on the keypad while powering up the pump will stop the Pump from starting in Power Failure Mode

Ln: n Low Noise mode, where "n" is the current setting: '0' = Disabled, '1' = Enabled.

A side effect of the AL-300's high precision micro-stepped motor driver are high frequency tones at very low pumping speeds. This mode minimizes the tones by reducing the micro-stepping, increasing pulsations.

REAR OF PUMP

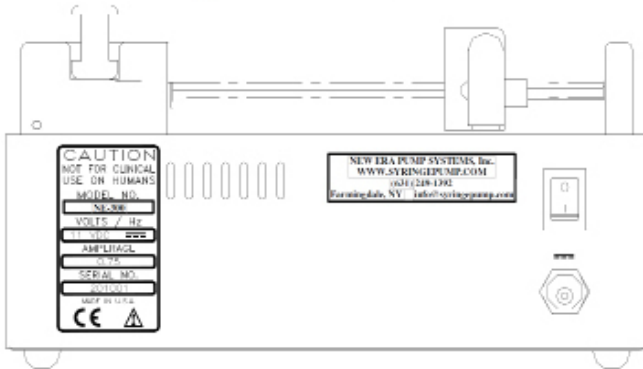

Fig. 3—Rear of the pump

TROUBLESHOOTING AND MAINTENANCE

Maintenance: Periodically, a small amount of all-purpose oil should be applied to the guide rods and lead screw.

The mechanism should be kept clean to prevent impeded operation. No other special maintenance or calibrations are needed

Pusher block makes a snap or click sound when the pump is started: This is a normal condition. When the pusher block is manually moved, the drive-nut may not have been fully engaged on the drive screw. The sound heard is the drive-nut engaging on the drive screw.

ACCESSORIES

Syringes and Plumbing Supplies

See www.SyringePump.com for an assortment of syringes and plumbing supplies

Syringe Heater

See www.SyringeHeater.com for details.

Flexible heating pads that wraps around the syringe. Thermo-Kinetic Heat Clamping controller will heat a syringe to a set temperature up to 100 C.

Firmware Upgrade

Contact your dealer to determine the current available version of the pumps internal firmware.

SPECIFICATIONS

Mechanical & Electrical

Syringe sizes.....	Up to 60 mL (140 ML partially filled)
Number of syringes.....	1
Motor type.....	Step motor
Motor steps per revolution.....	400
Microstepping.....	1/8 to 1/2 depending on motor speed
Advance per step.....	0.2126 μ m to 0.8504 μ m depending on motor speed
Motor to drive screw ratio.....	15/28
Drive screw pitch.....	20 revolutions/inch
Power connector:.....	2.1 mm, center positive, DC
Voltage at DC connector.....	12 V DC at full load
Amperage.....	750 mA at full load
Power supply type.....	Unregulated linear external wall adapter, country and power source specific (or compatible regulated power supply)
Power supply output rating.....	12 V DC @ 1000 mA
Dimensions.....	8 3/4" x 5 3/4" x 4 1/2" High (22.86 x 14.605 x 11.43 cm)
Weight.....	3.6 lbs. (1.63 kg)

Operational

Accuracy:.....	Within +/- 1% over length of syringe, exclusive of syringe variations.
Reproducibility:.....	+/- 0.1%
Maximum speed:.....	3.7742 cm/min
Minimum speed:.....	0.004205 cm/hr
Maximum pumping rate:.....	1257 mL/hr with a B-D 60 mL syringe
Minimum pumping rate:.....	0.73 μ L /hr with a B-D 1 mL syringe
Maximum force:.....	35 lbs. at minimum speed, 18 lbs. at maximum speed
Syringe inside diameter range:.....	0.100 to 50.00 mm

CUSTOM APPLICATIONS

For specialized and OEM applications, contact your dealer or New Era Pump Systems Inc. Custom modifications can be made to the mechanics or the firmware.

APPENDIX A: SYRINGE DIAMETERS & RATE LIMITS

Manufacturer	Syringe Size (ml)	Inside Diameter (mm)	Max.Rate (mL/hr)	Min. Rate (µl/hr)	Max. Rate) mL/min)
B-D	1	4.699	39.27	0.73	0.654
	3	8.585	131	2.434	2.184
	5	11.99	255.6	4.748	4.261
	10	14.43	370.3	6.876	6.172
	20	19.05	645.4	11.99	10.75
	30	21.59	829	15.4	13.81
	60	26.59	1257	23.35	20.95
HSW Norm-Ject	1	4.69	39.11	0.727	0.651
	3	9.65	165.6	3.076	2.76
	5	12.45	275.6	5.119	4.594
	10	15.9	449.6	8.349	7.493
	20	20.05	714.9	13.28	11.91
	30	22.9	932.6	17.32	15.54
	50	29.2	1516	28.16	25.27
Monoject	1	5.74	58.59	1.088	0.976
	3	8.941	142.1	2.64	2.369
	6	12.7	286.8	5.326	4.78
	12	15.72	439.4	8.161	7.324
	20	20.12	719.9	13.37	11.99
	35	23.52	983.8	18.27	16.39
	60	26.64	1262	23.44	21.03
	140	38	2568	47.69	42.8
Terumo	1	4.7	39.28	0.73	0.654
	3	8.95	142.4	2.646	2.374
	5	13	300.5	5.581	5.009
	10	15.8	443.9	8.244	7.399
	20	20.15	722.1	13.41	12.03
	30	23.1	949	17.63	15.81
	60	29.7	1568	29.13	26.14
SGE (gas tight)	0.25	2.303	9.432	0.176	
	0.5	2.303	18.86	0.351	
	1	4.606	37.73	0.701	
	2.5	4.606	94.36	1.752	
	5	10.3	188.6	3.504	
	Syringe Size (µL)	Inside Diameter (mm)	Max. Rate (µl/hr)	Min. Rate (µl/hr)	
	0.5	0.1	24.03	0.001	
	1	0.15	54.07	0.001	
	5	0.434	193.5	0.003	
	10	0.485	387	0.005	
	25	0.728	872	0.011	
	50	1.03	1745	0.022	
	100	1.457	3492	0.044	

Manufacturer	Syringe Size (ml)	Inside Diameter (mm)	Max.Rate (mL/hr)	Min. Rate (µl/hr)	Max. Rate) mL/min)
Hamilton Microliter	10	14.57	188.6	7.01	
	25	23.03	943.2	17.52	
	50	27.5	1344	24.98	
	100	34.99	2177	40.43	
	Syringe Size (µL)	Inside Diameter (mm)	Max. Rate (µl/hr)	Min. Rate (µl/hr)	
	0.5	0.103	18.86	0.001	
	1	0.146	37.91	0.001	
	2	0.206	75.47	0.001	
	5	0.326	189	0.003	

WARRANTY

WPI (World Precision Instruments) warrants to the original purchaser that this equipment, including its components and parts, shall be free from defects in material and workmanship for a period of two years* from the date of receipt. WPI's obligation under this warranty shall be limited to repair or replacement, at WPI's option, of the equipment or defective components or parts upon receipt thereof f.o.b. WPI, Sarasota, Florida U.S.A. Return of a repaired instrument shall be f.o.b. Sarasota.

The above warranty is contingent upon normal usage and does not cover products which have been modified without WPI's approval or which have been subjected to unusual physical or electrical stress or on which the original identification marks have been removed or altered. The above warranty will not apply if adjustment, repair or parts replacement is required because of accident, neglect, misuse, failure of electric power, air conditioning, humidity control, or causes other than normal and ordinary usage. The driver nut button and other parts subject to normal wear are not covered by the warranty.

To the extent that any of its equipment is furnished by a manufacturer other than WPI, the foregoing warranty shall be applicable only to the extent of the warranty furnished by such other manufacturer. This warranty will not apply to appearance terms, such as knobs, handles, dials or the like.

WPI makes no warranty of any kind, express or implied or statutory, including without limitation any warranties of merchantability and/or fitness for a particular purpose. WPI shall not be liable for any damages, whether direct, indirect, special or consequential arising from a failure of this product to operate in the manner desired by the user. WPI shall not be liable for any damage to data or property that may be caused directly or indirectly by use of this product.

Claims and Returns

Inspect all shipments upon receipt. Missing cartons or obvious damage to cartons should be noted on the delivery receipt before signing. Concealed loss or damage should be reported at once to the carrier and an inspection requested. All claims for shortage or damage must be made within ten (10) days after receipt of shipment. Claims for lost shipments must be made within thirty (30) days of receipt of invoice or other notification of shipment. Please save damaged or pilfered cartons until claim is settled. In some instances, photographic documentation may be required. Some items are time-sensitive; WPI assumes no extended warranty or any liability for use beyond the date specified on the container

Do not return any goods to us without obtaining prior approval and instructions from our Returns Department. Goods returned (unauthorized) by collect freight may be refused. Goods accepted for restocking will be exchanged or credited to your WPI account. Goods returned which were ordered by customers in error are subject to a 25% restocking charge. Equipment which was built as a special order cannot be returned.

Repairs

Contact our Customer Service Department for assistance in the repair of apparatus. Do not return goods until instructions have been received. Returned items must be securely packed to prevent further damage in transit. The Customer is responsible for paying shipping expenses, including adequate insurance on all items returned for repairs. Identification of the item(s) by model number, name, as well as complete description of the difficulties experienced should be written on the repair purchase order and on a tag attached to the item.

** Electrodes, batteries and other consumable parts are warranted for 30 days only from the date on which the customer receives these items.*



WORLD
PRECISION
INSTRUMENTS